



Operation Manual

5 Port Air Operated Valve

PRODUCT NAME

VFA3000, 5000 Series

MODEL/ Series

SMC Corporation

Contents

Safety Instructions	2,3
Precautions on Design / Selection	4
Mounting	5
Piping	5
Lubrication	5
Air Supply	6
Operating Environment	6
Maintenance	6
Specific Product Precautions	7
Troubleshooting	8
Remedy	8



Safety Instructions

These safety instructions are intended to prevent hazardous situations and/or equipment damage. These instructions indicate the level of potential hazard with the labels of “Caution,” “Warning” or “Danger.” They are all important notes for safety and must be followed in addition to International Standards (ISO/IEC)*1), and other safety regulations.

*1) ISO 4414: Pneumatic fluid power -- General rules relating to systems
ISO 4413: Hydraulic fluid power -- General rules relating to systems
IEC 60204-1: Safety of machinery -- Electrical equipment of machines (Part 1: General requirements)
ISO 10218-1992: Manipulating industrial robots -Safety.
etc.



Caution

Caution indicates a hazard with a low level of risk which, if not avoided, could result in minor or moderate injury.



Warning

Warning indicates a hazard with a medium level of risk which, if not avoided, could result in death or serious injury.



Danger

Danger indicates a hazard with a high level of risk which, if not avoided, will result in death or serious injury.

Warning

1. The compatibility of the product is the responsibility of the person who designs the equipment or decides its specifications.

Since the product specified here is used under various operating conditions, its compatibility with specific equipment must be decided by the person who designs the equipment or decides its specifications based on necessary analysis and test results.

The expected performance and safety assurance of the equipment will be the responsibility of the person who has determined its compatibility with the product.

This person should also continuously review all specifications of the product referring to its latest catalog information, with a view to giving due consideration to any possibility of equipment failure when configuring the equipment.

2. Only personnel with appropriate training should operate machinery and equipment.

The product specified here may become unsafe if handled incorrectly.

The assembly, operation and maintenance of machines or equipment including our products must be performed by an operator who is appropriately trained and experienced.

3. Do not service or attempt to remove product and machinery/equipment until safety is confirmed.

1. The inspection and maintenance of machinery/equipment should only be performed after measures to prevent falling or runaway of the driven objects have been confirmed.

2. When the product is to be removed, confirm that the safety measures as mentioned above are implemented and the power from any appropriate source is cut, and read and understand the specific product precautions of all relevant products carefully.

3. Before machinery/equipment is restarted, take measures to prevent unexpected operation and malfunction.

4. Contact SMC beforehand and take special consideration of safety measures if the product is to be used in any of the following conditions.

1. Conditions and environments outside of the given specifications, or use outdoors or in a place exposed to direct sunlight.

2. Installation on equipment in conjunction with atomic energy, railways, air navigation, space, shipping, vehicles, military, medical treatment, combustion and recreation, or equipment in contact with food and beverages, emergency stop circuits, clutch and brake circuits in press applications, safety equipment or other applications unsuitable for the standard specifications described in the product catalog.

3. An application which could have negative effects on people, property, or animals requiring special safety analysis.

4. Use in an interlock circuit, which requires the provision of double interlock for possible failure by using a mechanical protective function, and periodical checks to confirm proper operation.



Safety Instructions

Caution

1. The product is provided for use in manufacturing industries.

The product herein described is basically provided for peaceful use in manufacturing industries.

If considering using the product in other industries, consult SMC beforehand and exchange specifications or a contract if necessary.

If anything is unclear, contact your nearest sales branch.

Limited warranty and Disclaimer/Compliance Requirements

The product used is subject to the following “Limited warranty and Disclaimer” and “Compliance Requirements”.

Read and accept them before using the product.

Limited warranty and Disclaimer

1. The warranty period of the product is 1 year in service or 1.5 years after the product is delivered.*2)

Also, the product may have specified durability, running distance or replacement parts. Please consult your nearest sales branch.

2. For any failure or damage reported within the warranty period which is clearly our responsibility, a replacement product or necessary parts will be provided.

This limited warranty applies only to our product independently, and not to any other damage incurred due to the failure of the product.

3. Prior to using SMC products, please read and understand the warranty terms and disclaimers noted in the specified catalog for the particular products.

***2) Vacuum pads are excluded from this 1 year warranty.**

A vacuum pad is a consumable part, so it is warranted for a year after it is delivered.

Also, even within the warranty period, the wear of a product due to the use of the vacuum pad or failure due to the deterioration of rubber material are not covered by the limited warranty.

Compliance Requirements

1. The use of SMC products with production equipment for the manufacture of weapons of mass destruction(WMD) or any other weapon is strictly prohibited.

2. The exports of SMC products or technology from one country to another are governed by the relevant security laws and regulation of the countries involved in the transaction. Prior to the shipment of a SMC product to another country, assure that all local rules governing that export are known and followed.



VFA3000, 5000 Series

Precautions for 5 Port Air Operated Valve 1

Be sure to read before handling.

Design / Selection

Warning

1. Confirm the specifications.

Products represented in this manual are designed only for use in compressed air systems (including vacuum).

Do not operate at pressures or temperatures, etc., beyond the range of specifications, as this can cause damage or malfunction. (Refer to the specifications.)

Please contact SMC when using a fluid other than compressed air (including vacuum).

We do not guarantee against any damage if the product is used outside of the specification range.

2. Actuator drive

When an actuator, such as a cylinder, is to be driven using a valve, take appropriate measures (cover installation or approach prohibition) to prevent potential danger caused by actuator operation.

3. Intermediate stops

For 3-position closed center type, it is difficult to make a piston stop at the required position accurately due to the compressibility of air.

Furthermore, since valves and cylinders are not guaranteed for zero air leakage, it may not be possible to hold a stopped position for an extended period of time.

Please contact SMC if it is necessary to hold a stopped position for an extended period of time.

4. Effect of back pressure when using a manifold

Use caution when valves are used on a manifold, because an actuator may malfunction due to back-pressure.

Care should be taken if the 3-position exhaust-center or single acting cylinder is used.

If an actuator may malfunction due to backpressure, take the following countermeasures.

- Case of VFA3000

Use the individual exhaust spacer assembly (DXT155-17-1A).

- Case of VFA5000

Use the individual exhaust spacer assembly (DXT156-20-1A, DXT156-20-3A).

5. Holding pressure (including vacuum)

Since the valves are subject to air leakage, they cannot be used for applications such as holding pressure (including vacuum) in a pressure vessel.

6. Not suitable for use as an emergency shutoff valve, etc.

The valves listed in this manual are not designed for safety applications such as an emergency shutoff valve. If the valves are used for the mentioned applications, additional safety measures should be adopted.

7. Release of residual pressure

For maintenance purposes install a system for releasing residual pressure. Especially in the case of 3-position closed center valve type, ensure that the residual pressure between the valve and the cylinder is released.

8. 2-Position Double type

When using the 2-position double type for the first time, actuators may travel in an unexpected direction depending on the switching position of the valve. Implement measures to prevent any danger from occurring when operating the actuator.

9. Ventilation

Provide ventilation when using a valve in a confined area, such as in a closed control panel. For example, install a ventilation opening, etc. in order to prevent pressure from increasing inside of the confined area.

10. Do not disassemble the product or make any modifications, including additional machining.

It may cause human injury and/or an accident.

Caution

1. Operation in a low temperature condition

It is possible to operate a valve in extreme temperature, as low as -10°C. Take appropriate measures to avoid freezing of drainage, moisture etc. in low temperature.

2. Mounting orientation

Mounting orientation is free.



VFA3000, 5000 Series

Precautions for 5 Port Air Operated Valve 2

Be sure to read before handling.

Mounting

Warning

1. Operation manual

Install the products and operate them only after reading the operation manual carefully and understanding its contents. Also, keep the manual where it can be referred to as necessary.

2. Ensure sufficient space for maintenance activities.

When installing the products, allow access for maintenance.

3. Tighten threads with the proper tightening torque.

When installing the products, follow the listed torque specifications.

4. If air leakage increases or equipment does not operate properly, stop operation.

Check mounting conditions when air and power supplies are connected. Initial function and leakage tests should be performed after installation.

5. Painting and coating

Warnings or specifications printed or affixed to the product should not be erased, removed or covered up.

Please consult with SMC before applying paint to resinous parts, as this may have an adverse effect due to the solvent in the paint.

Piping

Caution

1. Preparation before piping

Before piping is connected, it should be thoroughly blown out with air (flushing) or washed to remove chips, cutting oil and other debris from inside the pipe.

2. Wrapping of pipe tape

When screwing piping or fittings into ports, ensure that chips from the pipe threads or sealing material do not enter the piping. Also, if pipe tape is used, leave 1 thread ridge exposed at the end of the threads.

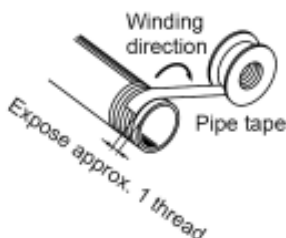

3. Closed center type

For closed center type, check the piping to prevent air leakage from the piping between the valve and the cylinder.

4. Connection of fittings

When screwing fittings into valves, tighten as follows.

- (1) Follow the procedures below when installing an SMC fitting, etc.

1) M5

After tightening the fitting by hand, use a wrench to tighten the fitting an additional approximately 1/6 to 1/4 turn. As a reference value, tightening torque is 1 to 1.5 N·m.

Note) If tightened excessively, the thread of the product may break or the gasket may deform. If tightened insufficiently, the thread of the product may become loose. In either case, air leakage can occur.

2) Rc

Tighten with the proper torque shown below.

Tightening Torque for Piping

Connection thread	Proper tightening torque (N·m)
Rc1/8	7 to 9
Rc1/4	12 to 14
Rc3/8	22 to 24
Rc1/2	28 to 30

- (2) Follow the procedure of the manufacturer when fittings other than SMC is used.

Lubrication

Warning

Lubrication

- 1) The valve has been lubricated for life by the factory and does not require any further.
- 2) If a lubricant is used in the system, use class 1 turbine oil (no additive), ISO VG32.
Once a lubricant is used in the system, lubrication must be continued because the original lubricant applied during manufacturing will be washed away.
If turbine oil is used, refer to the Material Safety Data Sheet (MSDS) of the oil.
- 3) Please contact SMC regarding class 2 turbine oil (with additives), ISO VG32.



VFA3000, 5000 Series

Precautions for 5 Port Air Operated Valve 3

Be sure to read before handling.

Air Supply

Warning

1. Type of fluids

Please consult with SMC when using the product in applications other than compressed air.

2. When there is a large amount of drainage.

Compressed air containing a large amount of drainage can cause malfunction of pneumatic equipment. An air dryer or water separator should be installed upstream from filters.

3. Drain flushing

If condensation in the drain bowl is not emptied on a regular basis, the bowl will overflow and allow the condensation to enter the compressed air lines. It causes malfunction of pneumatic equipment.

If the drain bowl is difficult to check and remove, installation of a drain bowl with an auto drain option is recommended.

For compressed air quality, refer to SMC's Best Pneumatics catalog.

4. Use clean air.

Do not use compressed air that contains chemicals, synthetic oils including organic solvents, salt or corrosive gases, etc., as it can cause damage or malfunction.

Caution

1. When extremely dry air is used as the fluid, degradation of the lubrication properties inside the equipment may occur, resulting in reduced reliability (or reduced service life) of the equipment. Please consult with SMC.

2. Install an air filter.

Install an air filter upstream near the valve. Select an air filter with a filtration size of 5 μ m or smaller.

3. Take measures to ensure air quality, such as by installing an aftercooler, air dryer, or water separator.

Compressed air that contains a large amount of drainage can cause malfunction of pneumatic equipment such as valves. Therefore, take appropriate measures to ensure air quality, such as by providing an aftercooler, air dryer, or water separator.

4. If excessive carbon powder is seen, install a mist separator on the upstream side of the valve.

If excessive carbon powder is generated by the compressor, it may adhere to the inside of a valve and cause it to malfunction.

For compressed air quality, refer to SMC's Best Pneumatics catalog.

Operating Environment

Warning

1. Do not use in an atmosphere having corrosive gases, chemicals, sea water, water, water steam, or where there is direct contact with any of these .
2. Do not use in a place subject to heavy vibration and/or shock.
3. The valve should not be exposed to prolonged sunlight. Use a protective cover.
4. Remove any sources of excessive heat.
5. If it is used in an environment where there is possible contact with oil, weld spatter, etc., exercise preventive measures.

Maintenance

Warning

1. Perform maintenance inspection according to the procedures indicated in the operation manual.

If handled improperly, malfunction and damage of machinery or equipment may occur.

2. Removal of equipment, and supply/exhaust of compressed air

When components are removed, first confirm that measures are in place to prevent workpieces from dropping, run-away equipment, etc. Then, cut off the supply pressure and electric power, and exhaust all compressed air from the system using the residual pressure release function.

For 3-position closed center type, exhaust the residual pressure between the valve and the cylinder.

When the equipment is operated after remounting or replacement, first confirm that measures are in place to prevent lurching of actuators, etc. Then, confirm that the equipment is operating normally.

3. Low frequency operation

Valves should be operated at least once every 30 days to prevent malfunction. (Use caution regarding the air supply.)

Caution

1. Drain flushing

Remove drainage from the air filters regularly.

2. Lubrication

Once lubrication has been started, it must be continued.

Use class 1 turbine oil (with no additive), ISO VG32 because if other lubricant oil is used, it may cause malfunction. Please contact SMC for suggested class 2 turbine oil (with additive), ISO VG32.



VFA3000, 5000 Series

Specific Product Precautions

Be sure to read before handling.

Used as a 3 port valve

Plugging one of the cylinder ports (A or B) enables use as a normally closed (N.C.) or normally open (N.O.) 3 port valve. It is convenient when 3 port valve is needed on a manifold, etc., but it can't be used in special applications such as using as a non-leakage valve. Use it with the exhaust port leaving open.

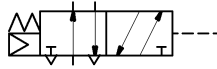
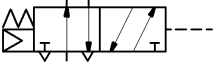
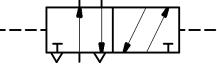
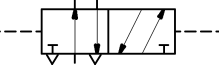
Plug		B port (CYL.1 port)	A port (CYL. 2 port)
Type of actuation		N.C.	N.O.
Number of pilot	Single	(X) plug (B)(A) 2 4  (R2)3 1 5(R1) (P)	(X) plug (B)(A) 2 4  (R2)3 1 5(R1) (P)
	Double	(X) plug (B)(A) 2 4  (R2)3 1 5(R1) (P)	(X) plug (B)(A) 2 4  (R2)3 1 5(R1) (P)

Pilot Pressure Range (Single pilot)

In the case of single type, be certain that pressure within operating pressure range be supplied to supply port, because return pressure is introduced from supply port {1(P)} for activation.

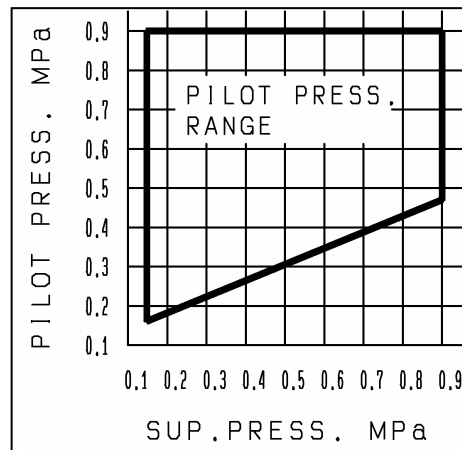

Air Operated Valve Mounting

Mount it so that there is no slippage or deformation in gasket, and tighten the valve mounting screw by tightening torque 1.4N·m.

Troubleshooting

Should any trouble be found during operation, trace the source of the trouble in the following order and take corrective action.

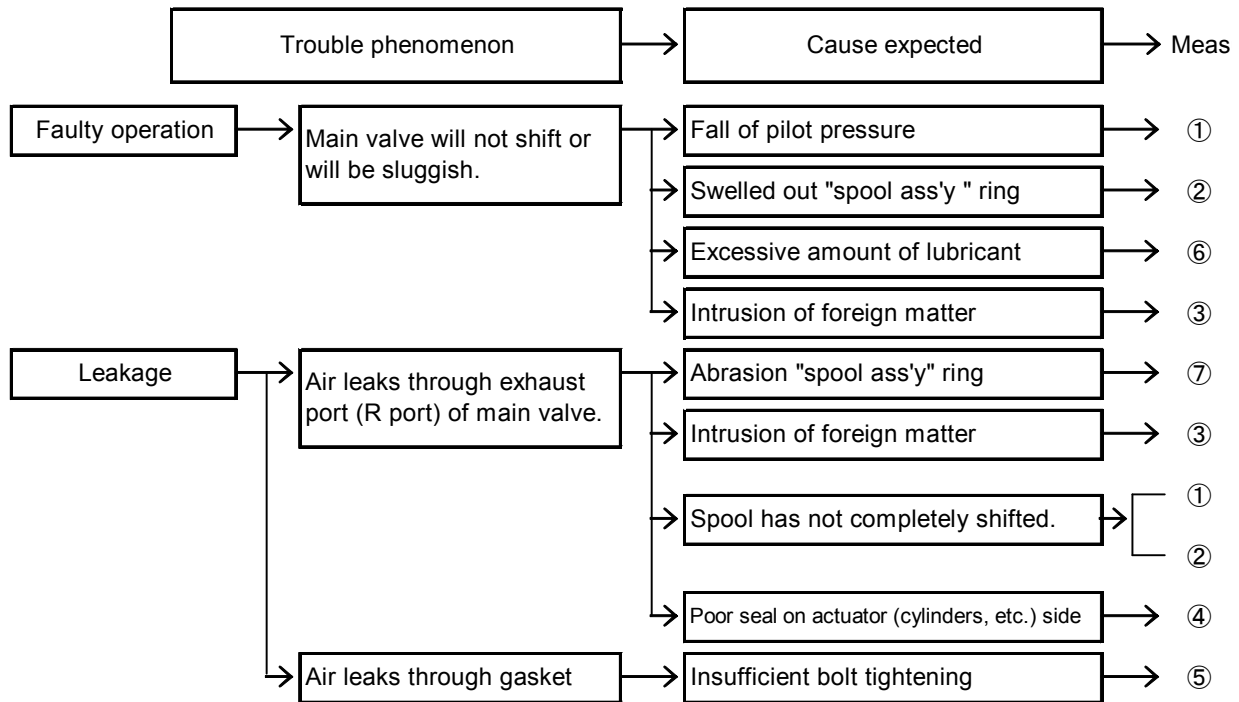

Remedy

No.	Remedy
①	Regulate pressure so that pilot pressure will fall within operating pressure range during operation.
②	·If wrong oil is used, completely air blow to remove oil, and replace valve. After valve is replaced, use turbine oil class 1 (ISO VG32). ·When a large quantity of drain is given and cannot carry out drain omission surely, install either an auto-drain or a dryer. The valve should be replaced.
③	In case of intrusion of foreign matter, to remove foreign matter by air blow of piping and then replace valve.
④	Repair or replace actuators.
⑤	After stopping air and re-tighten the bolts.
⑥	Reduce the amount of lubricant to the degree that no oil splashes out of the air exhaust port (R port).
⑦	Replace valve.

If no improvement is achieved in spite of the above countermeasure, inside of the valve may have some abnormality. In this case, stop using the valve immediately.

If any of followings are carried out, inside of the valve may have some failure. In this case, stop using the valve immediately.

1. Oil other than the specified one has been lubricated.
2. Lubrication has been stopped intermediately, or lubrication was suspended temporary.
3. Water splashed directly.
4. Strong impact was given.
5. Alien substance such as drain and particle got into. Drain or garbage invaded a valve.
6. Prohibited way of using the valve which is written at "Precautions" section in this operation manual was carried out excluding above-mentioned.

In addition, in the case of trouble, please send it back to the supplier for repair or replacement.

Revision history

A	Safety instructions	PR
---	---------------------	----

1st printing : My

SMC Corporation

4-14-1, Sotokanda, Chiyoda-ku, Tokyo 101-0021 JAPAN
Tel: + 81 3 5207 8249 Fax: +81 3 5298 5362
URL <http://www.smcworld.com>

Note: Specifications are subject to change without prior notice and any obligation on the part of the manufacturer.
© 2008 SMC Corporation All Rights Reserved

VF3000*-OMH0004-A